

# **Electronic Courtroom Technology Guide**

June 1, 2010

---

---

## Table of Contents

<b>Introduction</b> .....	<b>4</b>
<b>Touch Panel Display</b> .....	<b>5</b>
<b>Inputs to the Presentation System</b> .....	<b>6</b>
<b>Telephone Conferencing</b> .....	<b>7</b>
<b>Using the Document Camera for Evidence Presentation</b> .....	<b>8</b>
<b>Additional Document Camera Controls</b> .....	<b>10</b>
<b>Replacing the Document Camera</b> .....	<b>10</b>
<b>DVD/VCR</b> .....	<b>11</b>
<b>Presenting Evidence Using Your Laptop</b> .....	<b>13</b>
<b>Method 1</b> .....	<b>14</b>
<b>Method 2</b> .....	<b>16</b>
<b>Laptop Audio in the Courtroom</b> .....	<b>18</b>
<b>Additional Information Regarding the Courtroom Audio and Video</b> .....	<b>19</b>
<b>On-Screen Annotation (Telestrator)</b> .....	<b>20</b>
<b>Audio Enhancement for the Hearing Impaired and Language Translators</b> .....	<b>21</b>

---

---

**United States Bankruptcy Court  
Eastern District of Louisiana**

**Court Contact Information:**

**Chief Deputy Clerk**

Brian Richoux

(504) 589-7822

(504) 202-5176 (Cell)

[Brian\\_Richoux@laeb.uscourts.gov](mailto:Brian_Richoux@laeb.uscourts.gov)

**Additional contact information can be found on our website:**

**<http://www.laeb.uscourts.gov/Contacts/Directories.htm>**

---

---

## **Introduction**

Welcome to Electronic Evidence Presentation in the courtrooms of the United States Bankruptcy Court for the Eastern District of Louisiana. This guide is intended to assist you with utilizing the technology integrated into the courtrooms to its greatest advantage.

The Podium has been replaced by a Multimedia Presenter cart which now serves as the heart of the electronics in the courtroom. By accepting inputs from many different electronic devices (listed below), it allows counsel to display exhibits, video recordings, or multimedia presentations with the push of a button.



### **Multimedia Presenter Cart**

All of the equipment is controlled using the touch screen panel located on the podium. Simply touch the on-screen buttons to activate the input devices.

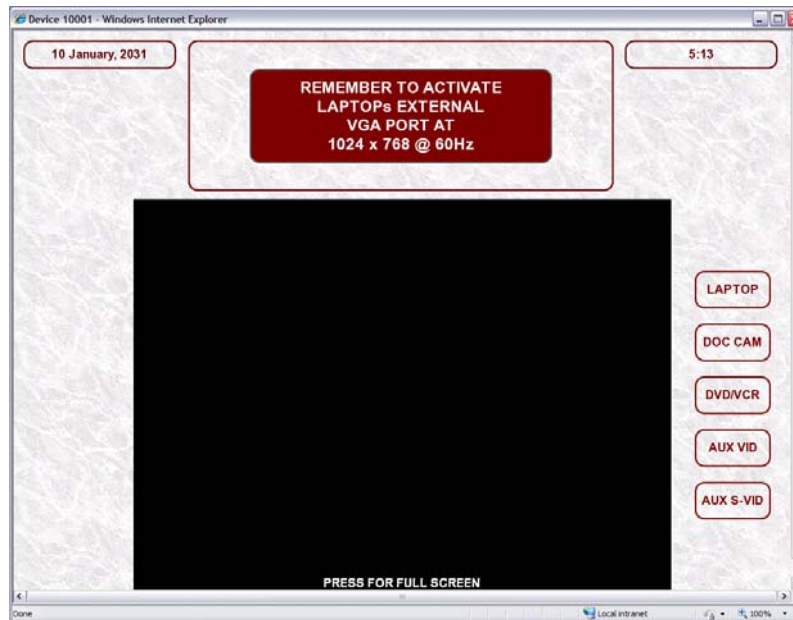

## **Touch Panel Display**

Counsel can now enhance their presentations and testimony with :

- Audio / Telephone Conferences
- Document Camera
- DVD / VCR Player
- Laptop Audio and Video inputs (laptop NOT supplied by the Court)
- On Screen Annotation (currently only available at the witness stand)
- Audio Enhancement for the Hearing Impaired and Language Translators

---

---

The Laptop output connectors - which become an input to the presentation system - as well as power, s-video, and RCA presentation system input connectors are concealed in a compartment toward the rear of the surface of the lectern.



**Auxiliary input connectors are located in this compartment.**

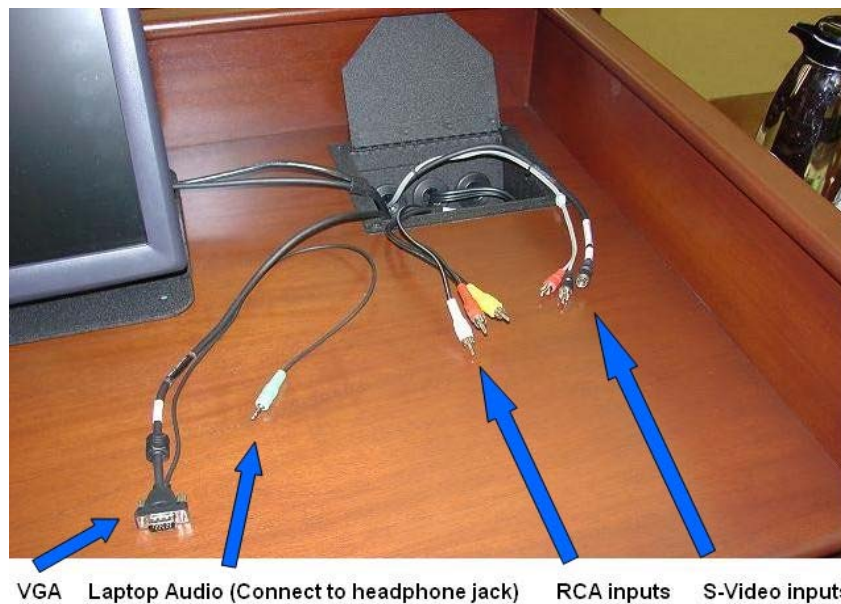

---

---

Before using the electronic evidence presentation equipment, for hearings and trials, we urge attorneys and their staff to arrange with the court for hands-on training and testing of their presentations on the available equipment.

## **Telephone Conferencing**

### **Section A:**

Procedures for telephonic court appearance in Section A can be found on the court's website. Go to [www.laeb.uscourts.gov](http://www.laeb.uscourts.gov), "Procedures", "Section A Procedures", and the section on telephonic court appearance.

### **Section B:**

To arrange for a telephonic appearance, contact the courtroom deputy by phone or email. Lisa will inform you whether the court will allow your telephonic appearance, and instruct you on the court's procedures.

**Note:** If participating in a hearing via Teleconferencing, Do not use a speaker phone or cell phone as these devices may interfere with the sound quality for the recording of the hearing. Parties must identify themselves each time they speak in order that the judge, courtroom and other telephonic participants know who is addressing the court

---

---

## **Using the Document Camera for Evidence Presentation**

Physical evidence such as printed documents, transparencies, slides, or x-rays may be displayed throughout the courtroom via the court's document camera.



The document camera is located in a pull-out drawer at the podium and is similar in function to an overhead projector.

### **To use the document camera:**

1. Open the drawer fully
2. Pull the arm upwards using the special pull ring
3. Being careful not to touch any of the buttons, adjust the Camera head (the lens should face DOWN toward the document area).
4. Place the evidence on the white surface.

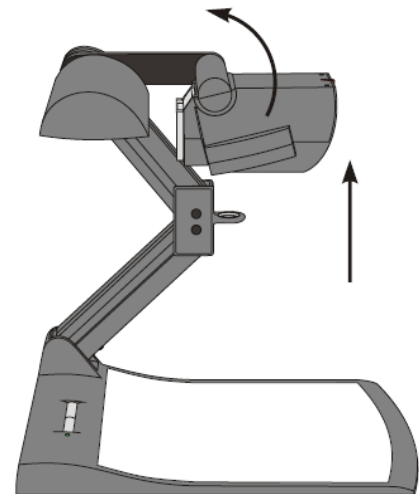



- 
- 
5. Touch the “DOC CAM” button on the touch screen monitor.

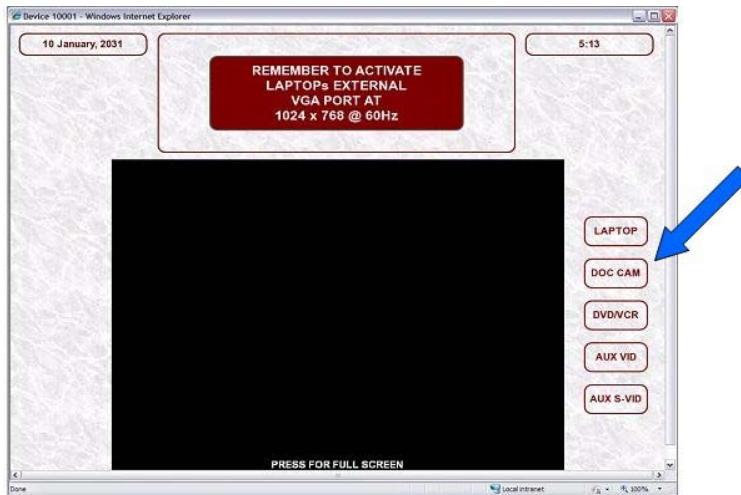

6. The document Camera Controls will appear.
7. Touch the “Power On” button on the touch screen.

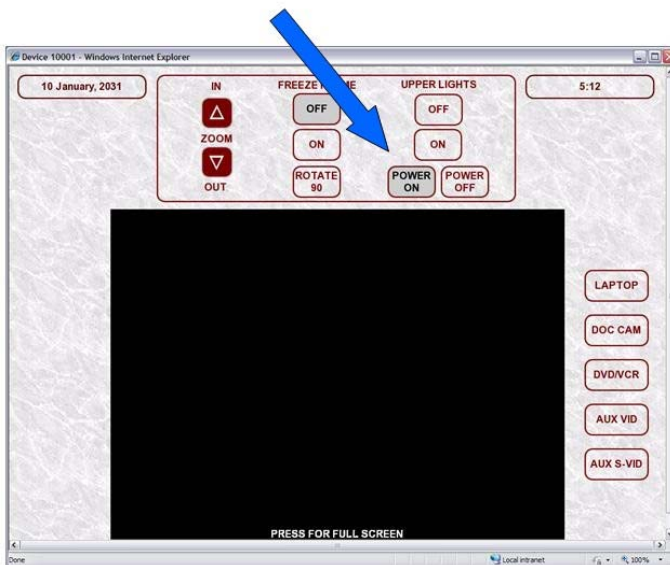

8. Use the “ZOOM IN”, and “ZOOM OUT” buttons on the touch screen to adjust the display.

---

---

## Additional Document Camera Controls on the Touch Panel:

- The “**ROTATE 90**” button will rotate the image 90° to accommodate wide pieces of evidence.
- The “**FREEZE FRAME**” “**ON**” button freezes the display, allowing you to remove the evidence from the camera while still displaying that evidence to the courtroom displays.
- The “**FREEZE FRAME**” “**OFF**” button returns the camera to a live display mode.

When finished using the document camera, you may want to restore it to its original location to allow more room behind the podium.

## Replacing the document camera:

1. After removing the evidence, turn off the camera using the “**POWER OFF**” button on the touch screen.

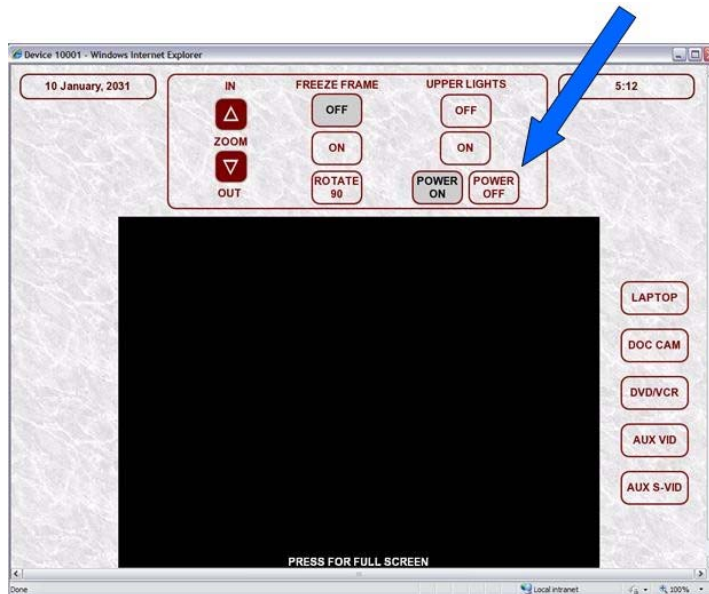

2. Rotate the camera head downward 90°
3. Pull the pull ring out and push the camera head down until it touches the lower surface
4. Carefully close the drawer once the document camera is returned completely to its original, folded position.

---

---

## DVD/VCR Player

After inserting the VCR tape or DVD, it is important that you use the controls (Play, Pause, Stop, Rewind, etc.) on the touch screen and not on the DVD/VHS player. Doing so may cause the player to lose synchronization with the touch panel.

To enable the DVD or VCR controls, first touch the “DVD/VCR” button on the touch screen (see image below).

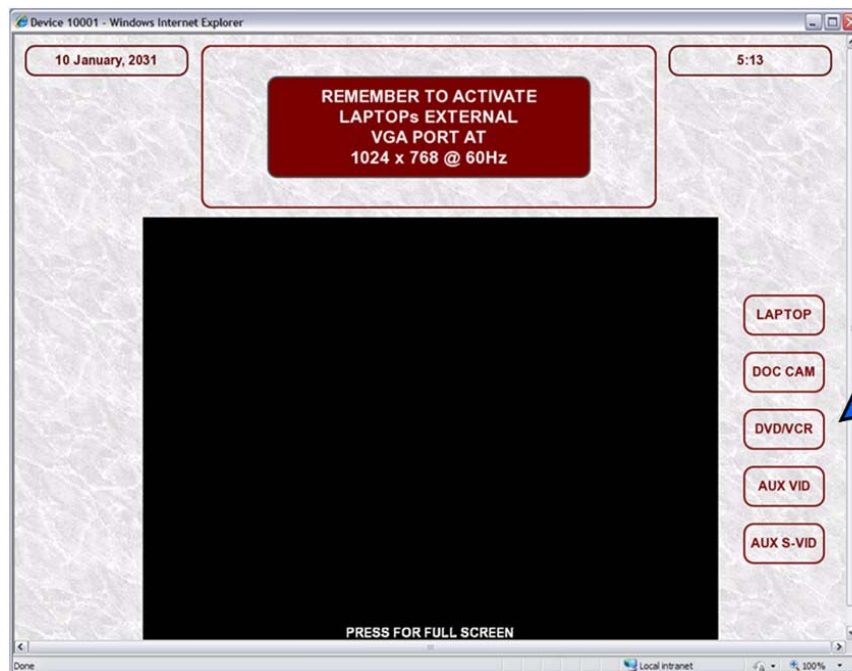

---

---

The interface for the DVD/VHS Player will appear on the touch screen display.

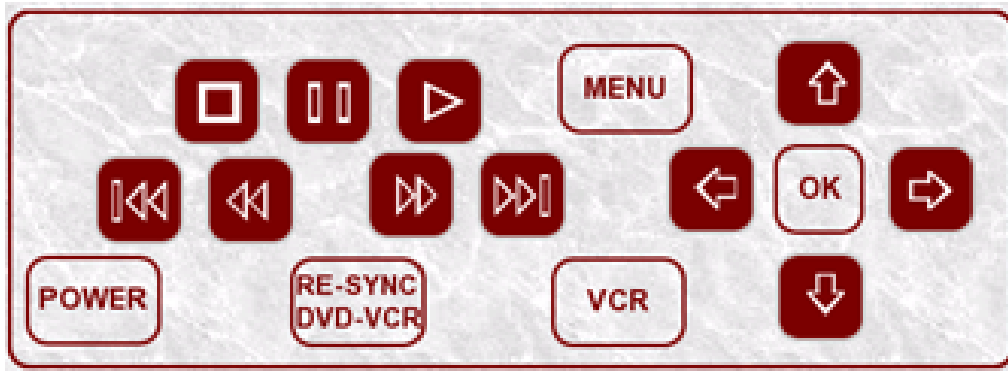

**DVD/V**

**CR Control Screen**

Press the “Power” button on the DVD/VCR control screen to turn on the DVD/VHS player.

The control screen utilizes standard DVD/VCR control symbols:

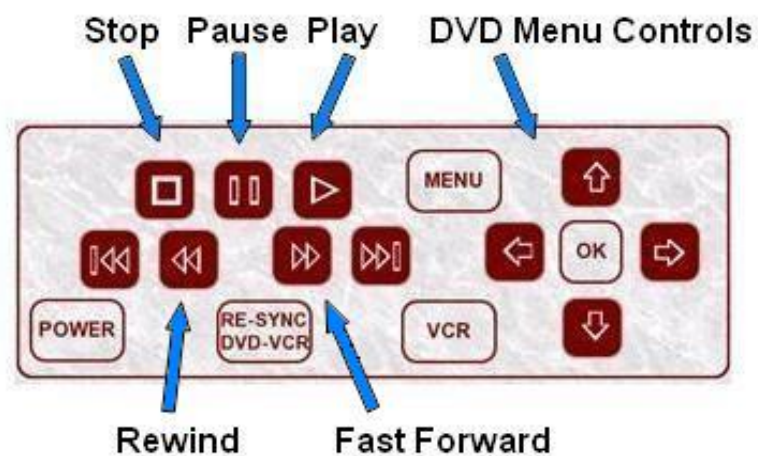

When finished with the DVD or VHS presentation, remove your DVD or cassette tape and press the on-screen “POWER” button again to turn off the device.

---

---

## **Presenting Evidence Using Your Laptop**

Electronic evidence such as digital documents, video, or computer generated slide shows and photographs may be broadcast throughout the courtroom using the court's video display system.

In order to connect your laptop to the court's display system, the laptop must have a VGA output port.



**Laptop External VGA port.**

1. Connect the VGA Cable located on top of the lectern or on either of the attorney tables to the laptop's VGA port.
2. If your presentation contains audio, connect the Audio cable to the headphone jack on your laptop.



**Lectern VGA**

**Cables**

**and Audio**

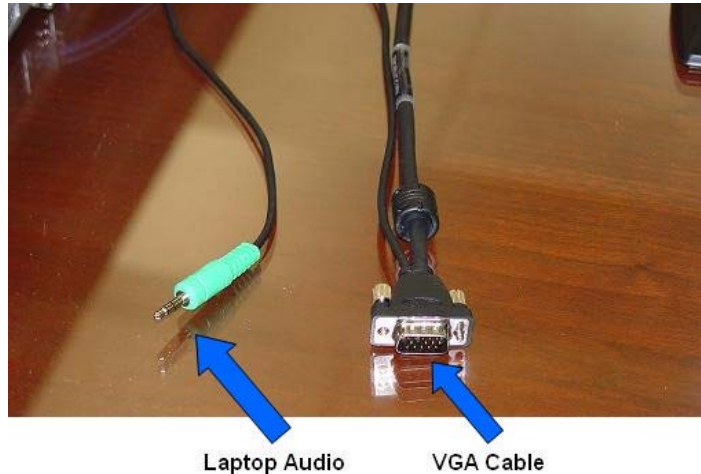

### **Attorney Table VGA and Audio Cables**

Once connected, there are two methods for displaying your laptop presentation. The first is easier to configure, but the second displays a cleaner look, free from the non-essential clutter, such as navigating to your data and opening up the presentation software.

**Important Note:** Both methods require your video resolution to be set to **1024x768**. You should create your presentation in that mode to ensure that it displays properly in the courtroom.

**Method 1:** Simply set your laptop screen resolution to 1024 x768 and enable the VGA output .

1. **Set the screen resolution:**
  - a. Right-click on a blank portion of your desktop.
  - b. Select “Properties” from the dialog box shown
  - c. Click the “Settings” tab.
  - d. In the “Screen Resolution” section, move the slider to 1024x768.
  - e. Click “OK”

- 
- 
2. **Enable the VGA output:** (this may vary for different laptops)
    - a. Hold down the function key (marked “fn”, usually in blue)
    - b. Press the CRT/ LCD button (Usually F5 or F8, it will either be marked “LCD/CRT” or have a monitor symbol). Typically each press of the function key combination advances one step through the cycle: laptop LCD only, both displays on, external VGA display only, and then repeats the cycle.



**External Monitor Key**



**Hold the ‘Fn’ key and press the ‘F8’ key (external monitor).**

**Method 2:** Add the courtroom display as a secondary display to your laptop. Navigate to your document(s) using your laptop. When you are ready, the document can then be moved to the courtroom display.

---

---

1. **Add the courtroom display as an ‘extended’ display**

Right-click on a blank portion of your desktop.

- a. Select “Properties” from the dialog box shown
  - b. Click the “Settings” tab.
  - c. In the “Screen Resolution” section, move the slider to 1024x768.
  - d. Click the check box labeled: ‘Extend my Windows desktop to this monitor’
  - e. Use the same function key combination as in step 2 above to enable both the laptop and VGA port (extended monitor).
2. Open the document that you wish to present. To display your document to the courtroom, click the “restore down” button in the upper right-hand corner of the application. It is found between the “minimize” and “close” buttons, and is represented by two overlapping squares.



**Restore Down**

3. Now click and hold the navbar (the title bar of your document window) and drag it to the right of the laptop screen. It will now appear on the courtroom screens. You will have to watch the courtroom screens to navigate your mouse pointer for the next step.
4. Click the “Maximize” button in the upper right-hand corner of your document. It will have replaced the “restore down” button and be represented by a square with a bold upper border. Your document is now displayed in the courtroom.





**Maximize**

5. Repeat steps 2 -4 for any additional documents.

---

---

## **Laptop Audio in the Courtroom**

Audio can be played in the courtroom from your laptop. Any audio file, or multimedia file that contains audio and is playable on your computer, can be broadcast throughout the courtroom by plugging the supplied audio cable from the lectern or attorney table to the headphone jack on your laptop.

1. Plug the audio cable from the lectern into the audio jack on your laptop.

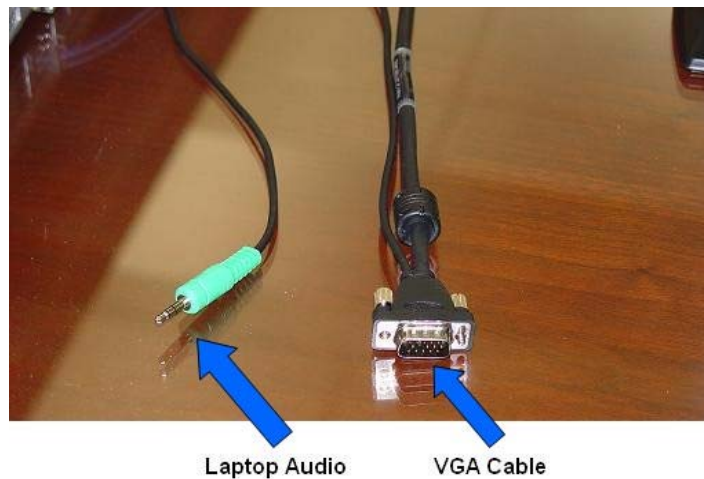

### **VGA and Audio**

### **Cables**

2. Adjust the laptop volume to a comfortable level

---

---

## **Additional Information Regarding the Courtroom Audio and Video**

1. The audio in the courtroom is a monaural signal, which means the audio is the same in both sides of the headset.
2. Disable system sounds such as key clicks as they will be reproduced along with your program material and can be distracting. Prior to the proceeding, you can test this by plugging a set of external speakers or headphones into the headphone output.
3. Some laptops have applications which monitor what devices are plugged into output ports (such as headphones or microphones) and configuring this software in advance will reduce mis-configurations.
4. DO NOT use your internal DVD drive for pre-recorded DVD presentations, such as a movie. Your laptop graphics card and DVD player software will attempt to maximize output resolution to produce the best possible image for your laptop which is much higher than the courtroom electronics can accept. This will result in broadcasting audio but no video in the courtroom. Use the DVD/VHS player integrated into the courtroom electronics for such presentations. However, large audio or video files (.wmv, .mov, mp3, etc.) can be burned to a recordable DVD and displayed from your laptop as these DVDs are formatted differently.
5. Most wireless interface devices like mice and screen pointers use radio signals to transmit their signal to the receiver in or at the laptop. The pre-amplification circuits used in the courtroom microphones are sensitive to these signals and will pick up these radio emissions and reproduce them in the courtroom speakers. Always use a corded device to minimize courtroom distraction.
6. Also, although your laptop may be capable of recording audio and/or video, please remember that such recordings are prohibited.

***REMEMBER:***

*To ensure that your exhibits are displayed correctly in the courtroom, contact the chief deputy to schedule an opportunity to test your laptop and familiarize yourself with the control panels available to you.*

---

---

## On-Screen Annotation (Telestrator)

The witness stand is outfitted with telestration. The witness has the ability to draw on the screen or highlight certain sections of any presentation. By simply touching the screen, the witness can draw with his/her finger on the exhibit, and it will be transmitted to all displays in the courtroom.

If you lightly tap the screen a colored arrow will be displayed at that location on all of the screens throughout the courtroom

The corners of the witness screen are labeled:

**COLOR** - Touching the screen near that corner changes the color of the subsequent annotations. The new color will be temporarily displayed in the lower right hand corner of the monitor. Each time the “Color” corner is pressed the color of the annotations will cycle to the next available color.

**UNDO** - Touching the screen near that corner erases the LAST annotation.

**CLEAR** - Touching the screen near that corner will clear all annotations.

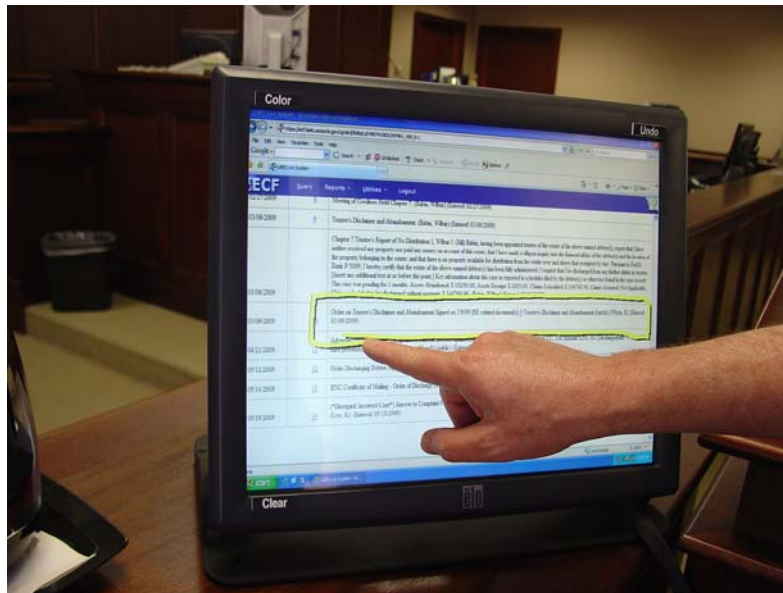

---

---

## Audio Enhancement for the Hearing Impaired and Language Translators

The courtrooms are outfitted with a number of infrared headphones to assist the hearing impaired, and can also be used for language translation if a translator is provided.



Located at the base of the headset are several switches:

1. Turn on the headset using the On/Off Volume switch
2. Select which channel (s) you wish to hear
  - a. Channel 1 broadcasts the courtroom audio
  - b. Channel 2 broadcasts any audio translation (if available)
  - c. The infinity symbol “∞” broadcasts channel 1 into the right ear and channel 2 into the left ear.
3. Place the ear pieces in the ears and allow the device to rest about the neck, with the white lettering facing away from your body. (Wearing the headset backwards - white lettering inward - will cause signal degradation and static to be heard)

**NOTE:** These are line of sight receivers. They will not work outside of the courtroom. There must be a line of sight to one of the infrared transmitters placed at either end of the courtroom.

### Infrared Transmitters



**Courtroom front**



**Courtroom rear**

If live audio translation is required, contact the chief deputy.